

Three Phase Multi Level Inverter with Reduced Number of Switches for Grid Connected Solar Systems Using Various PWM Techniques

G. Devid Paul¹

¹*M-tech Student Scholar*

Department of Electrical & Electronics Engineering,

R.V.R&J.C College of Engineering, ChowdaVaram;

Guntur (DT); A.P, India

G. B. Sankara Rao²

²*Associate Professor*

Department of Electrical & Electronics Engineering,

R.V.R&J.V College of Engineering, ChowdaVaram;

Guntur (DT); A.P, India

Abstract: In recent days Multilevel inverter (MLI) technologies become an incredibly main choice in the area of high power medium voltage energy control. Though multilevel inverter has a number of advantages it has drawbacks in the vein of higher levels because of using more number of semiconductor switches. This may leads to vast size and price of the inverter is very high. So in order to overcome this problem the new multilevel inverter is proposed with reduced number of switches. In recent days variable voltage speed drives play an important role in many industries. Basically three phase multilevel inverters are used in various industrial applications and the scheme called Pulse Width Modulation scheme is the most commonly used scheme on the inverters to generate variable voltage & frequency. This paper describes a new Three-phase eleven level inverter topology for grid connected photo voltaic (PV) or solar system using a carrier based PWM control scheme. This new topology has reduced number of switches for an increased number of levels when compared to conventional inverter. Here PWM switching scheme is used to control the switches in this multilevel inverter and this inverter is fed from a solar PV. By using this inverter topology, the harmonics is reduced and efficiency is enhanced significantly.

Key Words: Multilevel inverter, PWM technique, total harmonic distortion, LC filter, Grid, solar system

1. Introduction

Power electronic devices play a major role in the conversion and control of electric power, especially to extract power from renewable energy sources like photovoltaic array and wind energy [1]. Conversion of DC to AC power can be done with the help of inverters (single phase or three phases). Conventional bipolar inverters produce alternating staircase waveforms with higher harmonics. Thus, the multilevel inverters (MLI) were developed [2]. This paper provides a new three phase configuration to produce the 11-level output with less total harmonic distortion (THD) in its output voltage. IPD, APD, CO and VF PWM techniques were used to produce switching pulses [3]. The cascaded H-bridge (CHB) configuration has lesser number of components as compared to the conventional diode clamped or capacitor clamped inverters [4]. It contains single phase inverters connected in series with separate DC sources that can be derived from renewable energy sources like solar PV cell, bio fuel cell or wind turbine [5]. Each single phase inverter produces two DC voltage levels. Bridges with separate DC sources are cascaded to each other for more DC levels. The switches operate at fundamental frequency of 50Hz. The diode clamped MLI has 20 switches, 90 diodes and 10 main DC-bus capacitors per phase to produce an 11-level staircase as the output voltage. The capacitor clamped MLI uses 20 switches, 45 clamping capacitors and 10 main DC-bus capacitors per phase whereas the cascaded H-bridge inverter uses only 24 switches per phase to produce the same output [6-7]. This paper describes a single phase inverter configuration with eight switches and three DC sources.

A three phase multilevel inverter is obtained by interconnecting three single phase inverters to a star connected pure resistive load with a common earth point. Therefore, this circuit offers lesser gate control circuitry, lesser cost, lesser heating, more ease of installation and lesser electromagnetic interference. The performance of the inverter using IPD, APD, CO and VF PWM methods is shown [8]. A passive series LC filter is designed to produce a sine wave from the staircase inverter output. The purpose of the output LC filter is attenuating voltage ripples due to the inverter switching [9].

This paper proposes a power developed by photovoltaic system is DC. To convert this DC power a photovoltaic inverter is used. Improving the output waveform of the inverter helps to reduce the harmonic content in the current injected into the grid in a grid connected system.

2. Proposed Topology and Its Operation

The proposed inverter configuration has eight switches and three DC sources per phase as shown in Fig.1 The series combination among the three DC sources V_{dc} , $2V_{dc}$ and $2V_{dc}$ can be used to produce eleven DC levels at the inverter output in a single cycle.

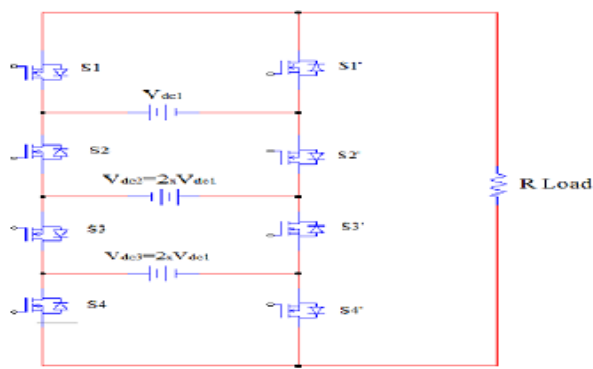

Fig.1 Proposed configuration for single phase inverter operation

Table.1 shows the conducting switches at different operating states. $+V_{dc}$ level voltage is obtained by turning on the switches S_1 , S_{2B} , S_{3B} and S_{4B} together. Similarly, all the DC output voltage levels are obtained as shown in TABLE.1

Switching states in 11-level inverter

Output Voltage	S1	S2	S3	S4	S1B	S2B	S3B	S4B
$+5V_{dc}$	1	0	1	0	0	1	0	1
$+4 V_{dc}$	0	0	1	0	1	1	0	1
$+3 V_{dc}$	1	0	1	1	0	1	0	0
$+2 V_{dc}$	0	0	1	1	1	1	0	0
$+ V_{dc}$	1	0	0	0	0	1	1	1
0	0	0	0	0	1	1	1	1
$- V_{dc}$	0	1	1	1	1	0	1	1
$-2 V_{dc}$	1	1	0	0	0	0	1	1
$-3 V_{dc}$	0	1	0	0	1	0	1	1
$-4 V_{dc}$	1	1	0	1	0	0	1	0
$-5V_{dc}$	0	1	0	1	1	0	1	0
0	1	1	1	1	0	0	0	0

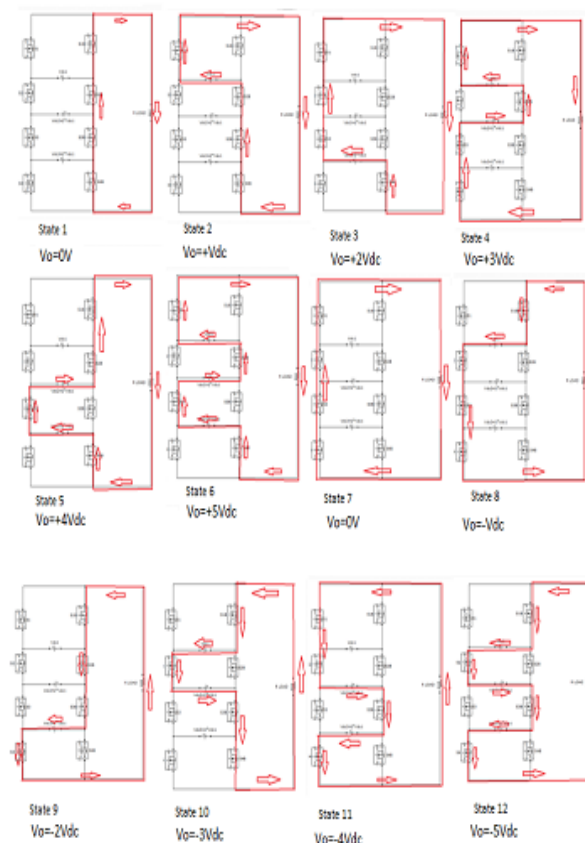

Fig.2. States corresponding to each Output voltage level

3. Modulation Schemes

To control the frequency and harmonics of the output voltage of the inverter, we must select the most appropriate PWM technique. The sinusoidal PWM (SPWM) method has been applied to the power switches, in which a reference sinusoidal wave of fundamental frequency is compared to high frequency carrier wave(s). The level, frequency or amplitude of the multiple carrier signals are varied based on the PWM technique. The modulation indices are kept same in all the methods for comparison. Amplitude modulation index is the ratio of the amplitude of the reference sine wave to the amplitude of the carrier waves. Frequency modulation index, is defined as the ratio of the frequency of carrier wave to the frequency of the modulating wave. Amplitude modulation index m_a and frequency modulation index m_f are given by (1) and (2) respectively.

$$m_a = A_m / A_c \quad (1)$$

$$m_f = f_c / f_m \quad (2)$$

The PWM techniques discussed in this paper are In Phase Disposition (IPD) type level shift pulse width modulation (LS-PWM), Anti-Phase Disposition (APD) PWM, Carrier Overlap (CO) PWM and Variable Frequency (VF) PWM. The amplitude modulation index m_a is maintained at 0.9 and the frequency modulation index m_f at 200. The RMS value of the fundamental component of the output voltage and the total harmonic distortion (THD) are observed by using simulation results. In all the PWM techniques, 'N' number of carrier signals is used to obtain 2N+1 voltage levels.

3.1. In-Phase Disposition Level-Shift PWM (IPD-LSPWM) Method

The carrier signals are level shifted in this PWM technique. They have the same amplitude of 1 V and a frequency of 10 kHz. The level shifted carrier signals are compared with a diode bridge rectified reference sine wave which is at fundamental frequency, as illustrated. The different levels of the output wave is detected and decoded to produce the pulses required to trigger each switch in the inverter. In order to obtain a three phase inverter, the sine wave is phase shifted by 120°.

3.2. Anti-Phase Disposition Level-Shift PWM (APD-LSPWM) Method

Each carrier signal is out of phase with neighboring carrier signals by 180° and have the same amplitude and frequency. The carrier signals are compared with the reference sine wave (which is at fundamental frequency) to produce required gate pulses.

3.3. Carrier Overlap PWM (Co-PWM) Method

This strategy utilizes level shifted carrier waves of the same frequency and amplitude. They are in phase with each other and also overlap each other. They are compared to a diode bridge rectified reference sine wave in order to produce the gate pulses.

3.4. Variable Frequency PWM (VF-PWM) Method

In the level-shifted carrier waves have the same amplitude. The lowermost carrier wave has very high frequency, 10kHz followed by 8kHz, 6kHz, 4kHz and the uppermost carrier signal has lowest frequency, 2kHz. They are compared with the reference sine wave with fundamental frequency to produce required switching pulses.

4. Grid Connected Solar System

The block diagram of the proposed grid connected PV system is shown in the figure. It consists of a PV system, proposed multi level inverter to interface with the grid.

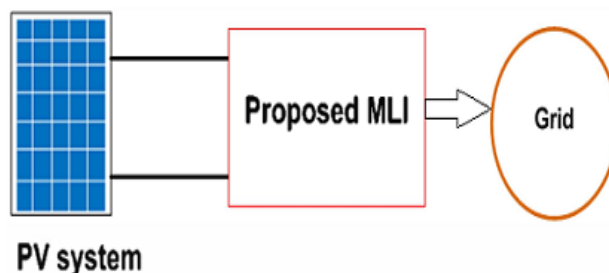

Fig.3. Grid connected solar system (PV)

From fig.4 the PV cell directly converts the solar energy into electricity in the form of dc [8]. The voltage obtained from the PV is converted into ac using the proposed inverter. Finally the proposed inverter is connected to the power grid with satisfying the grid requirements such as phase angle, frequency and amplitude of the grid voltage.

5. Matlab / Simulink Results

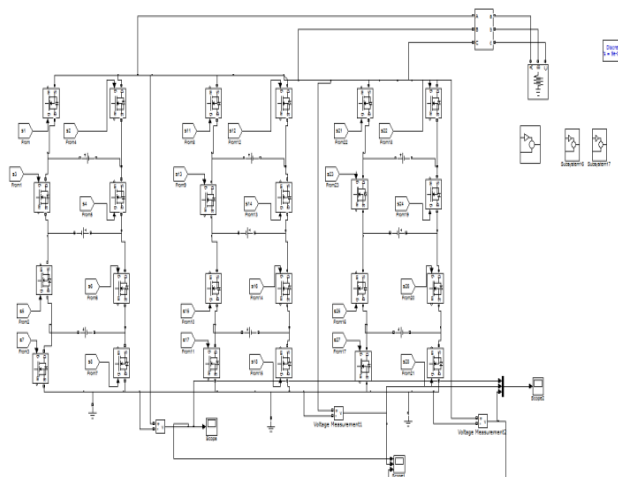

Fig.4. Matlab / simulation circuit of configuration for three phase inverter operation.

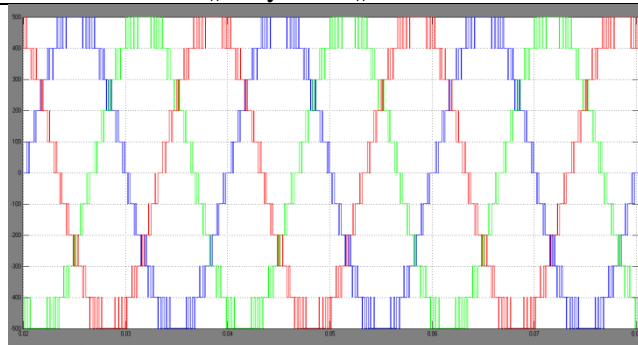

Fig.5. Output voltage waveform for three phase 11 level inverter using IPD-LSPWM technique

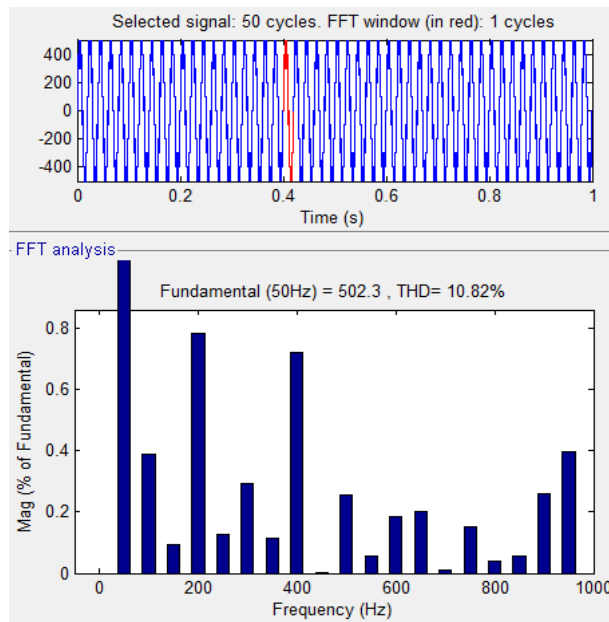

Fig.6. FFT Analysis of the harmonic spectrum for IPD-LSPWM technique

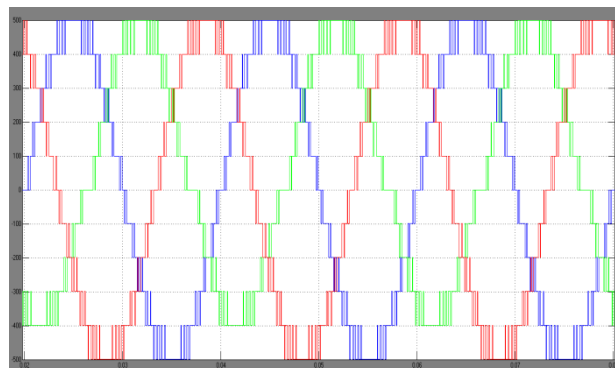

Fig.7. Output voltage waveform for three phase 11 level Inverter using APDLSPWM technique.

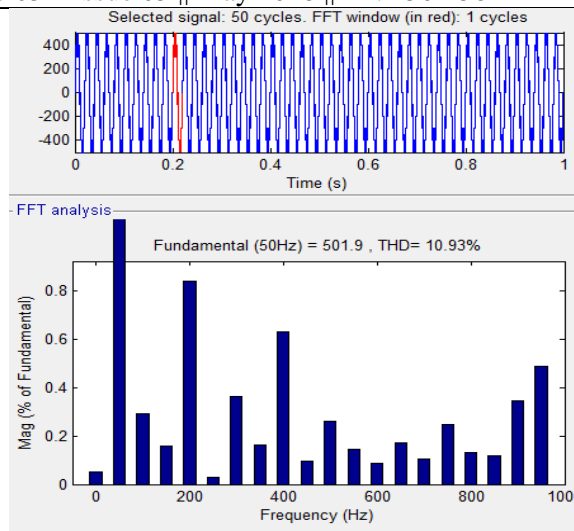

Fig.8. FFT Analysis of the harmonic spectrum for APD-LSPWM technique

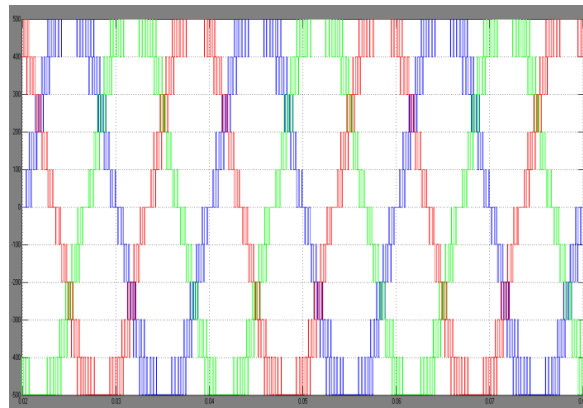

Fig.9. Output voltage waveform for three phase 11 level Inverter using CO-PWM technique

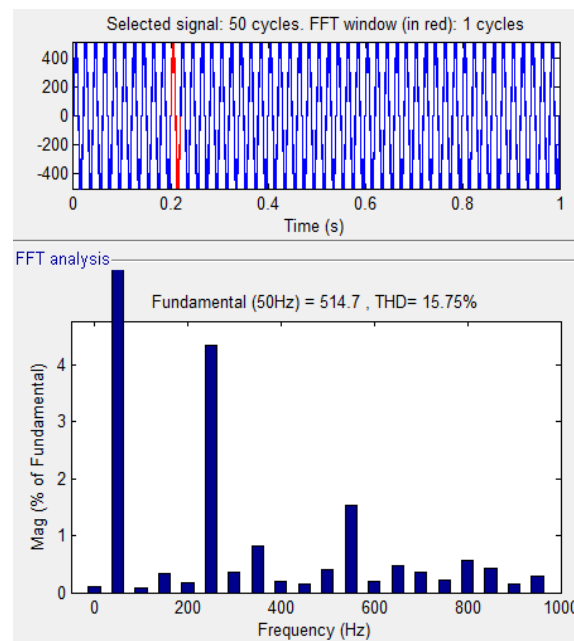

Fig.10. FFT Analysis of the harmonic spectrum for CO-PWM technique

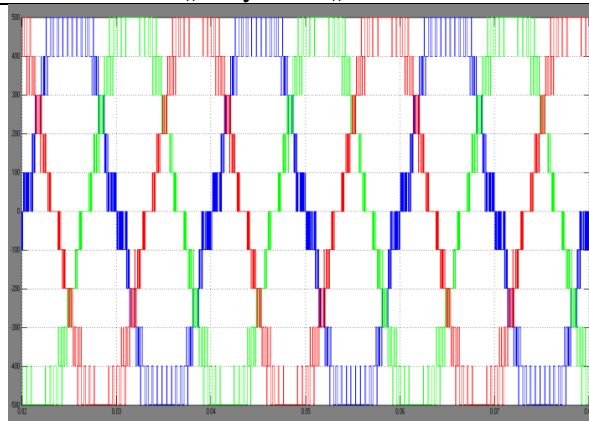

Fig.11. Output voltage waveform for three phase 11 level Inverter using VF PWM technique

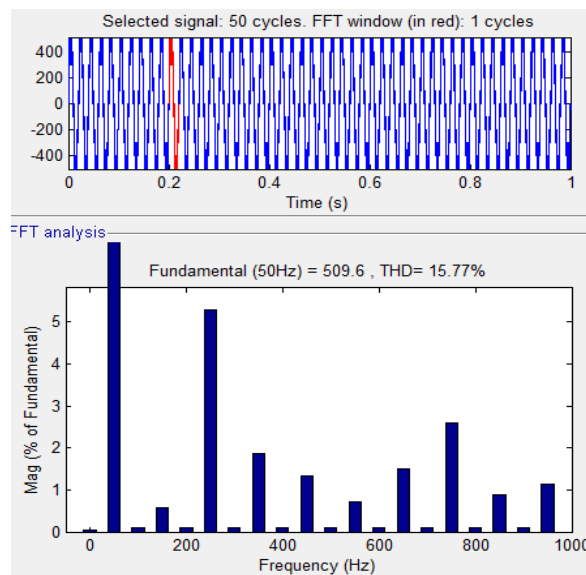

Fig.12. FFT Analysis of the harmonic spectrum for VF-PWM technique

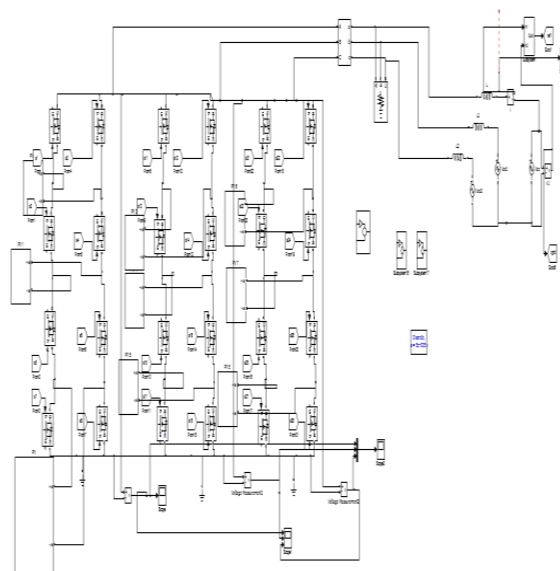

Fig.13. Matlab/simulation circuit of configuration for three phase inverter operation with grid connected solar system.

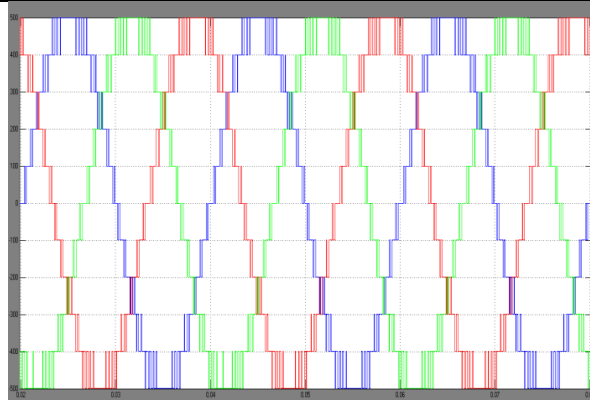

Fig.14. Output voltage waveform for three phase 11 level inverter using IPD-LSPWM technique with grid connected solar system

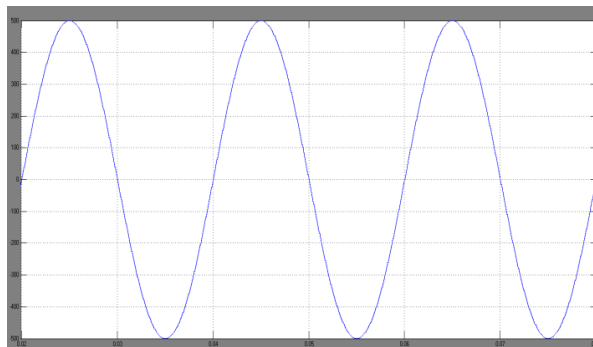

Fig.15 Grid voltage

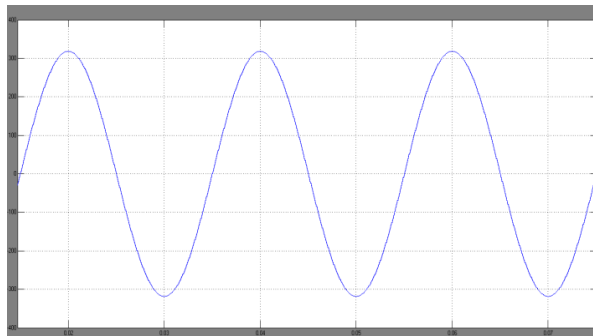

Fig.16 Grid current

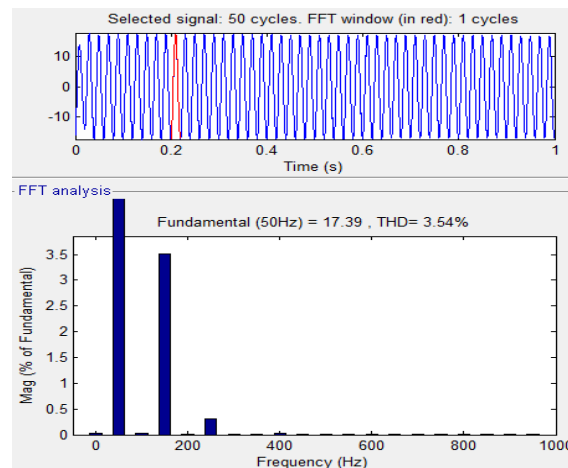

Fig.17. FFT Analysis of the harmonic spectrum for IPD-PWM technique with grid connected solar system.

6. Conclusion

Three-phase multi level inverter topology is proposed in this paper. The proposed inverter has the advantages of reducing the number of switches and gate drives circuits by compared with the conventional Multi-level inverter. Therefore, the proposed inverter exhibits the merits of simplified gate drive, high efficiency, low cost compared to the other topologies for the same number of phase voltages levels. Multilevel inverters offer improved output waveforms and lower THD. This paper has presented switching scheme for the proposed multilevel inverter. The behavior of the proposed multilevel inverter was analyzed in detail. By controlling the modulation index, the desired number of levels of the inverter's output voltage can be achieved. Also a grid connected solar system is simulated in MATLAB/SIMULINK. From the simulation results it was observed that the control algorithm works well with changing atmospheric conditions. Using multilevel inverters in such grid connected solar system considerably reduces the THD level of the current injected into the grid.

References

- [1]. Rodriguez J., Lai J.S., Pengf.Z. 'Multilevel Inverters: A Survey Of Topologies, Controls, And Applications'. IEEE Trans. Ind. Electron., Vol.49, No. 4, Pp. 724-738, Aug. 2002.
- [2]. Malinowski, M.; Gopakumar, K.; Rodriguez, J.; Perez, M.A; , "A Survey On Cascaded Multilevel Inverters," Industrial Electronics, IEEE Transactions On , Vol.57, No.7, Pp.2197-2206, July 2010.
- [3]. Balamuruganc.R., Natarajan S.P., Vidhya V.' A New Modified Hybrid Bridge Multilevel Inverter Using Less Number Of Switches'. International Conference On Computation Of Power, Energy, Information And Communication (ICCPEIC), 2013, Pp 1-6.
- [4]. Mohamed AS, Norman Mariun, Nasrisulaiman, Marnran M. Radzi:"A New Cascaded Multilevel Inverter Topology With Minimum Number Of Conducting Switches," IEEE Innovative Smart Grid Technologies-Asia (ISGT ASIA) 2014.
- [5]. Khomfoi S., Praisuwana N., Tolbert L.M. : "A Hybrid Cascaded Multilevel Inverter Application For Renewable Energy Resources Including A Reconfiguration Technique," Electrical Engineering And Computer Science, The University Of Tennessee, USA
- [6]. Salodkar P., Sandeep N., Kulkarni P.S., Ajaykumar R.Y.: 'A Comparison Of Seven-Level Inverter Topologies For Multilevel DC-AC Power Conversion'. IEEE International Conference On Power Electronics, Drives And Energy Systems (PEDES), 2014.
- [7]. Beigi L.M.A., Azli N.A., Khosravi F., Najafi E., Kaybhosravi A: 'A New Multilevel Inverter Topology With Less Power Switches', International Conference On Power And Energy, 2012, IEEE , 2-5 December 2012.
- [8]. Vadhiraj S., Narayanaswamy K., Divakar B.P.;, "Generic SPWM Technique For Multilevel Inverter," Electrical And Electronics Dept, REVA Institute Of Technology And Management, Bangalore, India.
- [9]. Hyosung Kim, Seung-Ki Sui, "Analysis On Output LC Filters For PWM Inverters", Power Electronics And Motion Control Conference, 17-20 May 2009. IPEMC, 2009. IEEE 6th International, Pp. 384 - 389.

1. Author Profile:



G. Devid Paul received the bachelor of technology from Acharya nagarjuna university college of engineering and technology in 2016 in electrical and electronics engineering. I have done in my b.tech project on fault analysis by using WAVELET TRANSFORM.

2. Author Profile:

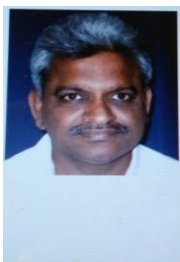

G. Basva Sankara Rao received mtech in high voltage engineering, J.N.T.U-KAKINADA, AP. I participated in non conventional energy sources By Gudlavalluru engg college, AP. Sponsered projects in design of relaying equipment for various applications. I had 29 years teaching experience in EEE.