

## Modelling and Simulation of Three Phase Shunt Active Power Filter and Hybrid Filter For VSD

Kuldeep Pippal<sup>1</sup>, Kiran Pathekar<sup>2</sup>, Akash Shrivastava<sup>3</sup>, Jeevan Matele<sup>4</sup>

<sup>1</sup>M.Tech scholar, Kopal Institute of Science and Technology, Bhopal, India

<sup>2</sup>M.Tech scholar, Kopal Institute of Science and Technology, Bhopal, India

<sup>3</sup>M.Tech scholar, Kopal Institute of Science and Technology, Bhopal, India

<sup>4</sup>M.Tech scholar, Kopal Institute of Science and Technology, Bhopal, India

---

**Abstract:** Power Quality improvement always becomes a challenge for power system engineers. Harmonics play significant role in deteriorating power quality. Harmonic distortion in electric distribution system is increasingly growing due to the widespread use of nonlinear loads in industries such as variable Speed Drives. Large considerations of such loads raise harmonic voltage and currents in an electrical system to unacceptable high levels that can adversely affect the system. IEEE standards have defined limits for harmonic voltages and harmonic currents. Various power filters have been considered a potential candidate to bring these harmonic distortions within the IEEE limits. This paper deals with active power filter (APF) based on simple control along with comparison with hybrid power filters. The hybrid power filter combines the compensation characteristics of resonant passive and active power filters. A voltage source inverter with pulse width modulation (PWM) is employed to form the Active Power Filter. A vector controlled variable Speed Drive is considered as nonlinear load on ac mains for the elimination of harmonics by the proposed schemes. MATLAB model of the various schemes are simulated and obtained results are studied and compared.

**Keywords:** APF-Active Power Filter, variable Speed Drive, PWM Controller, hybrid filter, THD.

---

### I. Introduction:

Solid state power conversion devices are widely used to control and convert ac power to feed large number of electrical loads. The loads can be electrical furnaces, voltage controllers, SMPS, UPS, Variable Speed Drives. These non-linear loads draw a large harmonic current with active power from ac mains. The presence of harmonic current component causes poor utilization of system, overheating which deteriorate life expectancy of other equipments. Various conventional method of series inductors were employed to reduce harmonics but there are certain demerits of size, weight, noise and resonance. The problems of harmonic pollution were re-organised and concept of active filters were introduced by gyugi and strycula[7] for elimination of harmonics in systems with non linear loads.

A large number of attempts were made for harmonic elimination on three phase[2]-[6].The proposed active power filter (APF) consists of three phase voltage source inverter with an energy storage capacitor at dc bus as shown. The APF is connected with load through filtering inductor. A PI controller is employed to generate reference currents with reference voltage and dc storage capacitors as its inputs. The carrier less hysteresis PWM current control over the supply current is used to generate the gating signals for the device of APF.

The proposed hybrid active power filter is also implemented with a three phase PWM voltage source inverter and connected in series to the passive filter using a coupling transformer. The system proposed control schemes is analogous to the control scheme adopted for active filters. The active power filter forces the utility line currents to become sinusoidal and in phase with respective phase to neutral voltage improving compensation characteristics of the passive filter.

This paper is aimed to propose various filtration techniques to mitigate harmonics with variable Speed Drive connected to 1 HP induction motor as non-linear load. The harmonic analysis and suppression techniques are performed at various speeds on a simulation model.

### II. Basic Principle of Operation

Fig.1 shows the basic block diagram of three phase active power filter principle in a closed loop manner. Three phase active power filter concept uses harmonic current compensation with 180 degree phase shift to harmonic currents generated from non-linear loads. Thus a shunt active power filter uses the concept of

injection of harmonic currents into the ac system of same amplitude but opposite in phase to that of harmonic currents.

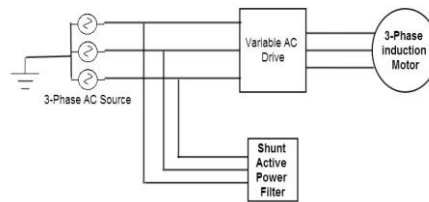

Fig.1 Basic block diagram of Active power filter

In general case,

lets assume the load current as combination of fundamental load current and harmonic current which can be expressed as

$$I_l = I_f + I_h \quad (1)$$

where  $I_f$  is fundamental component and  $I_h$  is three phase harmonic current active filter current is given by

$$I_{af} = I_h \quad (2)$$

supply current is given by

$$I_s = I_l - I_{af} \quad (3)$$

solving further

$$I_s = I_f + I_h - I_h$$

$$I_s = I_f \quad (4)$$

thus theoretically it is shown that harmonics are completely compensated by shunt active filter.

In a shunt active filter model Pulse width modulation (PWM) is employed to generate gating pulses to the switches of APF. The dc based load fed from diode bridge rectifier with a capacitor is a non-linear load on the ac mains. The proposed APF is to eliminate harmonics and to improve the power factor of supply. The major parts constituting APF are described in brief:

### 1. Voltage Source Inverter(VSI)

A single phase voltage source IGBT bridge with an energy storage capacitor on dc side, connected in parallel with the load-thus forming a voltage fed inverter. The full bridge inverter is built by four IGBTs that chosen according to their suitable ratings. Large size capacitor is connected to the inverter such that constant level of voltage could be maintained over each switching cycle.

### 2. PWM Controller

A simplified P-I (Proportional-Integral) control of the dc capacitor average voltage is used to generate reference current in phase with ac source voltage to result in unity power factor of the source current. The pulse width modulation (PWM) is employed to generate gating signal for IGBTs to control the phase and magnitude of the inverter output. PWM is chosen as a controller in this work due to its ability to reduce the distortion factor and lower order of harmonics as well besides that the phase and the magnitude of the full-bridge inverter can be easily changed.

### 3. Non-linear load

In this paper a three phase variable Speed Drive connected to a three phase induction motor is taken as non-linear load. The THD analysis and its elimination were done at various speeds. The simulation model is shown for various filtration schemes.

In hybrid filtration techniques a passive filter is connected in series with shunt active power filter through a coupling transformer or a mutual inductance[8][9]. The block diagram adopted in case of hybrid filter is shown in fig.2:

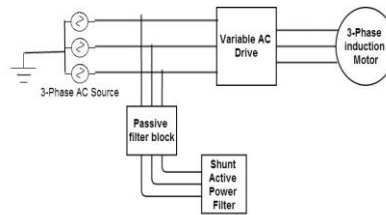

Fig. 2 Block diagram of hybrid filter

### III. Control Scheme

Fig.3 shows the control scheme for the APF system. DC bus voltage and supply voltage and current are sensed to control the APF[1]. The sensed dc bus voltage of the APF along with its reference value are processed in the P-I voltage controller. The truncated output of the P-I controller is taken as peak of source current. A unit vector in phase with the source voltage is derived using its sensed value. The peak source current is multiplied with the unit vector to generate a reference sinusoidal unity power factor source current. The reference source current and sensed source current are processed in hysteresis carrier less PWM current controller to provide gating signals for the MOSFETs of the APF. In response to these gating pulses, the APF impresses a PWM voltage to flow a current through filter inductor to meet the harmonic components of the load current. Since all the quantities such as dc bus voltage etc. are symmetric and periodic corresponding to the half cycle of the ac source. A corrective action is taken in each half cycle of the ac source resulting in fast dynamic response of the APF.

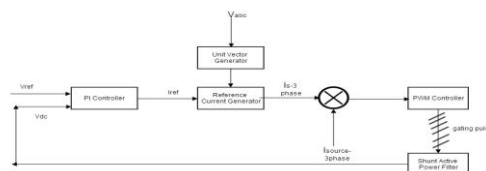

Fig.3 Control scheme for APF system

### IV. SIMULATION

Non linear Speed Drive load is simulated along with various filter schemes. First a simple system is shown in which three phase ac supply is connected to variable Speed Drive as shown in fig.4. Thus a harmonic analysis has been done on it. In next step the simulation model is connected with shunt active power filter as shown in fig.5. the internal filter model is shown in fig. 6 where the control mechanism or PWM is employed to generate gate signals using PI controller. Fig.7 shows a simulink model of a drive system connected to a hybrid filter in shunt. A hybrid filter comprises of a passive filter branch connected to active filter.

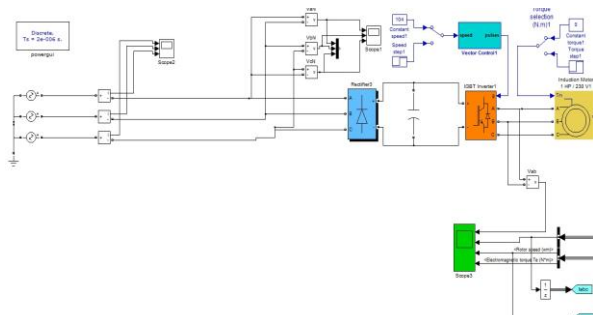

Fig.4 Simulation model when connected without any filter

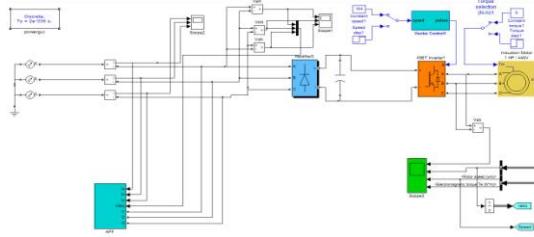

Fig.5 Simulation model with Shunt APF

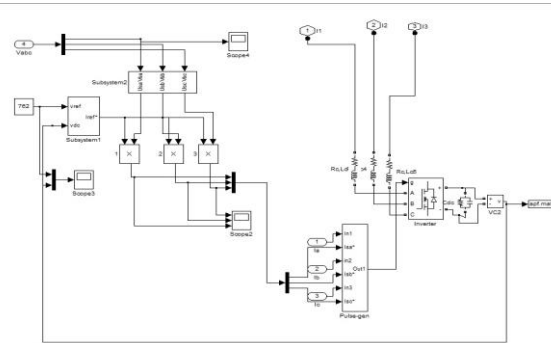

Fig.6 Shunt APF model with PI Controller

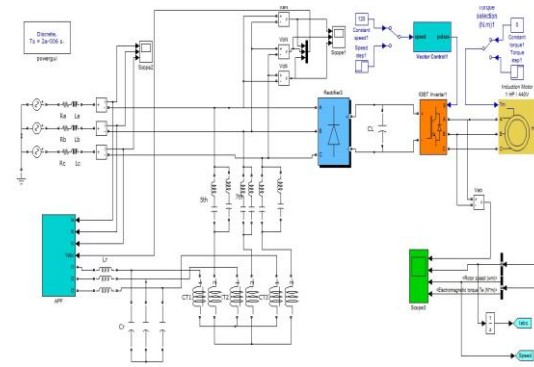
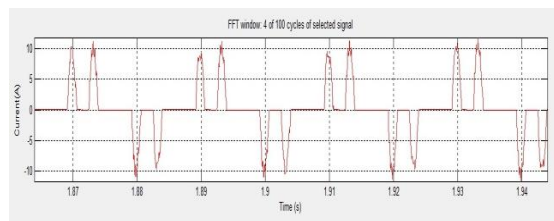

Fig. 7 Simulink model of Hybrid filter

## V. Simulation Results

A FFT analysis has been performed on various filtration schemes with different motor speeds



(i)

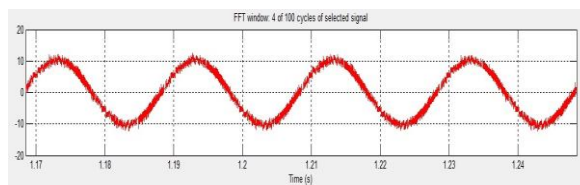

(ii)

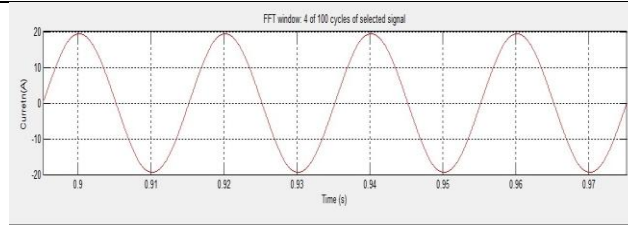

(iii)

Fig. 8 Current waveform at 78 rad/sec for  
 (i) no filter (ii) shunt active filter (iii) hybrid filter

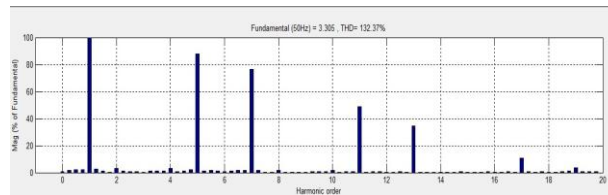

(i)

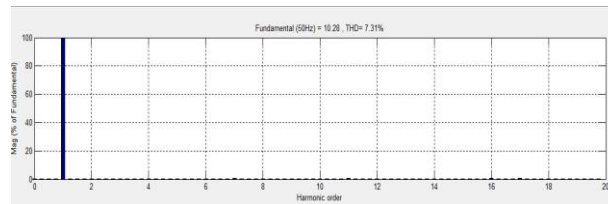

(ii)

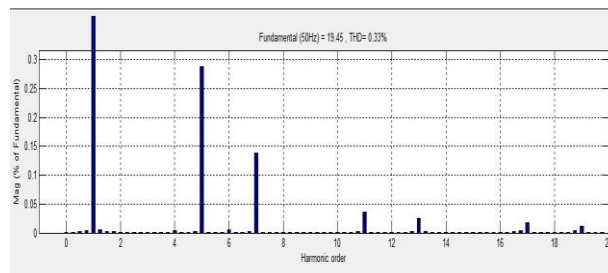

(iii)

Fig 9. Harmonic analysis at 78 rad/sec for  
 (i) No filter (ii) shunt active filter (iii) hybrid filter

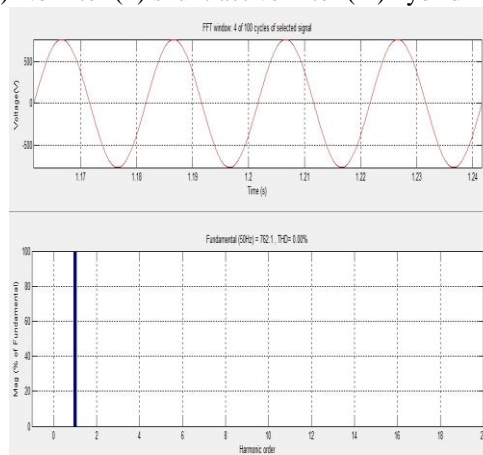

Fig. 10 Voltage waveform and THD with no filter at 78 rad/sec

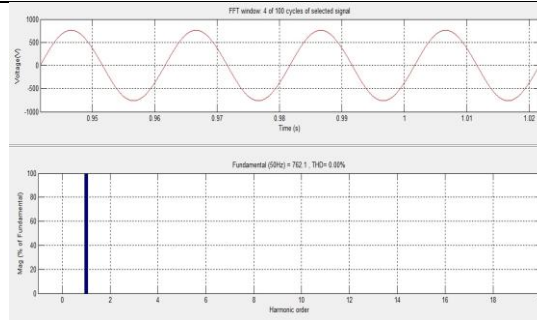

Fig. 11 Voltage waveform and THD with active filter at 78 rad/sec.

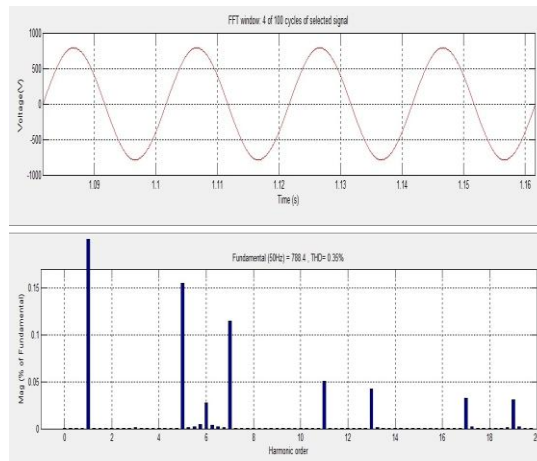
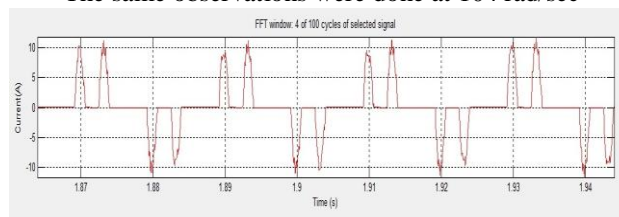
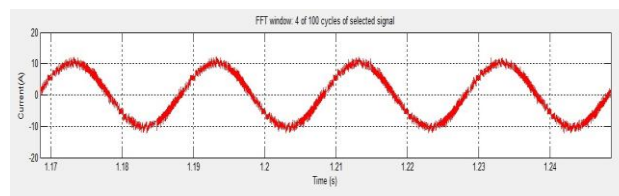

Fig. 12 Voltage waveform and THD with Hybrid filter at 78 rad/sec

The same observations were done at 104 rad/sec



(i)



(ii)

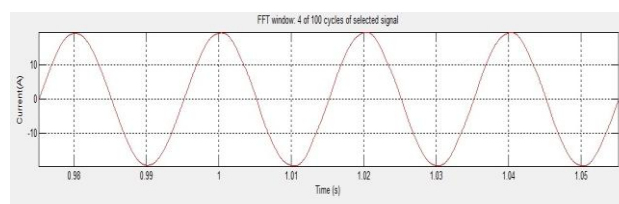

(iii)

Fig.13 Current waveform at 104 rad/sec for (i) No filter (ii) active filter (iii) hybrid filter

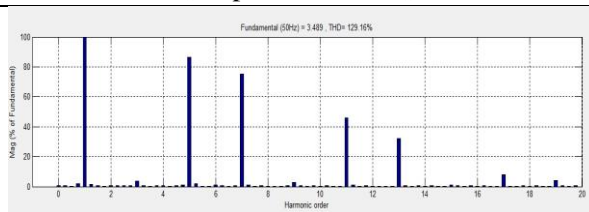

(i)

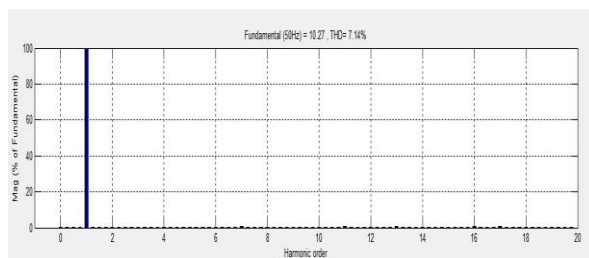

(ii)

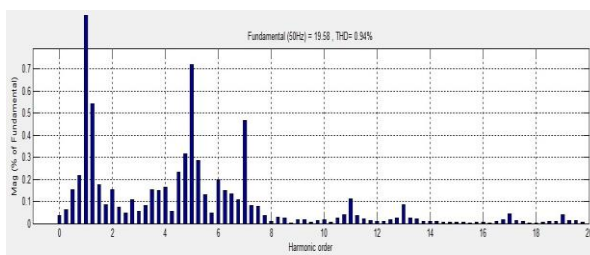

(iii)

Fig.14 Current THD at 104 rad/sec for (i) No filter (ii) active Filter (iii) Hybrid filter

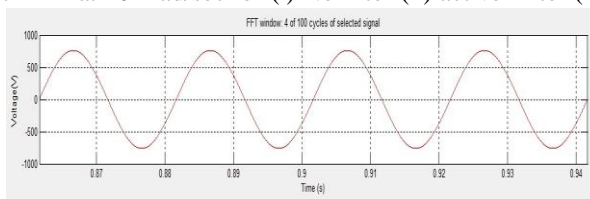

(i)

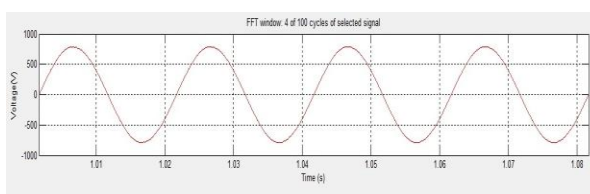

(ii)

Fig. 15 Voltage waveforms at 78 rad/sec for (i) Active filter (ii) Hybrid filter

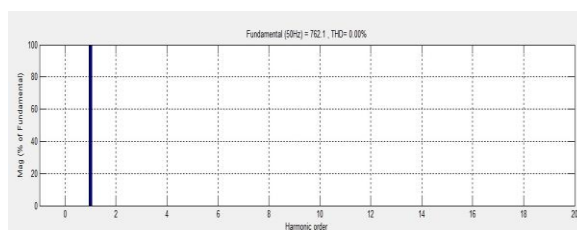

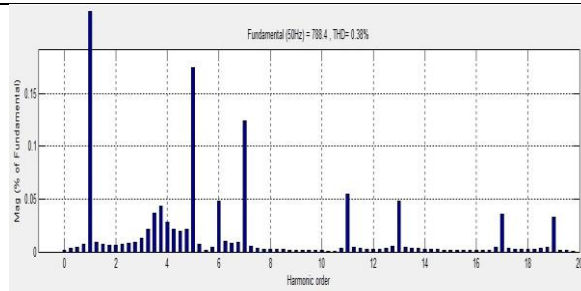

Fig. 16 Voltage THD at 104 rad/sec for (i) Active filter (ii) Hybrid filter

## VI. Summary

TABLE 1: Summary of all the results

S.N	Speed (rad/s)	Filter Used	Current THD	Voltage THD	Current THD Improvement	Voltage THD Improvement
1	78	No filter	139.37%	0.00%	-----	-----
2	78	Active filter	7.31%	0.00%	132.06%	0.00%
3	78	Hybrid filter	0.33%	0.35%	139.04	-0.35%
4	104	No filter	129.16%	0.00%	-----	-----
5	104	Active filter	7.14%	0.00%	122.02%	0.00%
6	104	Hybrid filter	0.94%	0.38%	128.22%	-0.38%

## VII. Conclusion

In this paper harmonic analysis and its suppression techniques were implemented using a simulation model with variable Speed Drive load. Fig. 8 shows the input end current in presence of no filter, active filter and hybrid filter at 78 rad/sec. motor speed. It has been observed that there is no voltage distortion when no filter scheme is employed and little harmonics in hybrid filter scheme. Fig. 13 and 14 shows the current waveforms and THD respectively of all three schemes. It has been seen that the percentage THD gets reduced with increase in speed of the motor connected at load end. Table 1 gives a brief summary of the experiments performed to eliminate harmonics. So it is concluded that PI controller based active filters can reduce the current percentage THD to around 7% with no voltage harmonics. The implementation of hybrid filters have provided with great results with current and voltage THD below 1% and within IEEE 519 standard limits.

## VIII. Appendixes

Circuit parameters

V=440V, Frequency= 50Hz

Active filter-

Rc= 0.1 ohm, Lc= 2mH

Cdc=4700microF, CL=500microF

Vdc=Vref= 762V

Hybrid filter-

Ra=0.25 ohm, La= 2.5mH

5<sup>th</sup> – L=6.22mH, C= 65microF

7<sup>th</sup> – L=3.17mH, C= 65microF

Cr= 6.75 microF, Lr= 6 mH

Motor- 440V, 50 Hz, 3 Phase squirrel cage induction motor



### IX. References

- [1]. Singh, B.; Al-Haddad, K.; Chandra, A.; , "A review of active filters for power quality improvement," *Industrial Electronics, IEEE Transactions on* , vol.46, no.5, pp.960-971, Oct 1999
- [2]. Akagi, H.; , "Control Strategy and Site Selection of a Shunt Active Filter for Damping of Harmonic Propagation in Power Distribution Systems," *Power Engineering Review, IEEE* , vol.17, no.1, pp.58, January 1997
- [3]. Z. Radulovik and A. Sabanovic, "Active filter control using a sliding mode approach", IEEE-PESC'94 conf. Record, pp. 177-182.
- [4]. P.Z. Peng, H. Akagi and A. Nnbae, "Compensation Characteristics of the Combined System of Shunt Passive and Series Active Filters". IEEE Transactions on Industry Applications, Vol. 29, No. 1 . llan./Feb. 1993, pp. 144-152.
- [5]. Bhattacharya and D. Divan. "Synchronous Frame Based Controller Implementation for a Hybrid Active Filter System". IEEE-1AS95 Conference Record, pp.253 1 -2540.
- [6]. Al-Zamil, A.M.; Torrey, D.A., "A passive series, active shunt filter for high power applications," *Power Electronics, IEEE Transactions on* , vol.16, no.1, pp.101,109, Jan 2001
- [7]. Gyugyi and E.C. Strycula, "Active AC Power Filters", IEEE-IAS Annual Meeting Record, 1976. pp. 529-535.
- [8]. Rivas, D. Moran, L.; Dixon, J.; Espinoza, J., "A simple control scheme for hybrid active power filter," Power Electronics Specialists Conference, 2000. PESC 00. 2000 IEEE 31st Annual , vol.2, no., pp.991,996 vol.2, 2000
- [9]. Mahesh Sitaram, I.; Padiyar, K. R.; Ramanarayanan, V., "Digital simulation of a hybrid active filter-an active filter in series with a shunt passive filter," *Power Quality '98* , vol., no., pp.65,71, 18 Jun 1998